



# TECAPRES®

Ø120mm · Low compression  
2800daN

## TPB 2800

VDI SAFETY



PED  
2014/68/EU

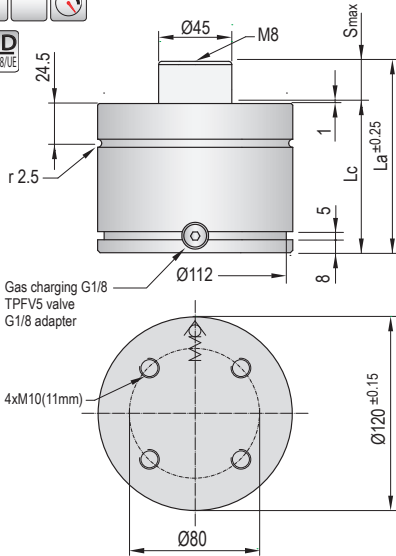

Gas charging G1/8  
TPFV5 valve  
G1/8 adapter

- Pressure medium **Nitrogen (N<sub>2</sub>)**
- Max. charging pressure **175 Bar**
- Min. charging pressure **35 Bar**
- Rod seal area **15,90 cm<sup>2</sup>**
- Operating temperature **0°C - 80°C**
- Force increase by temperature **0,33 %/°C**
- Max. stem speed **1,2 m/s**
- Maintenance kit **Kit B2800.1**



Maximum strokes / minute (at 20°C)

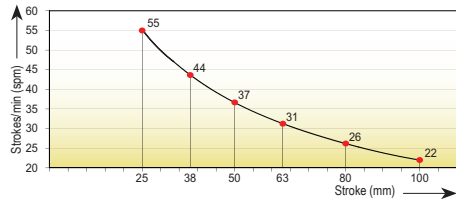

Code	S <sub>max</sub> mm	L <sub>a</sub> mm	L <sub>c</sub> mm	F <sub>a</sub> daN	90% F daN	100% F <sub>c</sub> daN	P Bar	V l	kg
TPB 2800x25	25	118	93	2800 ±5% (20°C)	3110	3155	175 (20°C)	0,339	4,80
TPB 2800x38	38	144	106		3165	3215		0,452	5,55
TPB 2800x50	50	168	118		3195	3250		0,556	6,25
TPB 2800x63	63	194	131		3215	3275		0,668	6,32
TPB 2800x80	80	228	148		3240	3300		0,816	7,15
TPB 2800x100	100	268	168		3255	3315		0,987	8,10

Force/stroke ratio

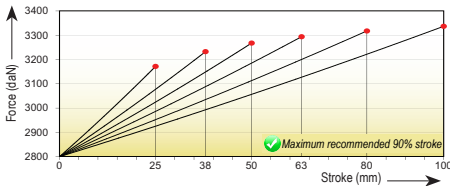

Initial force/charging pressure ratio

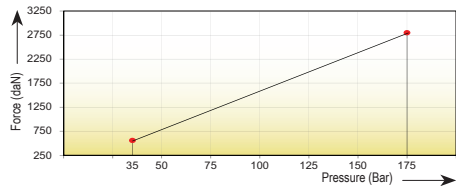

Assembly possibilities

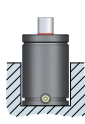

DROP-IN



SCREWS

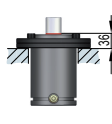

FS 120 · FSC 120



FP 120 · FPR 120



FB 120

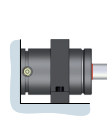

FI 120 · FI 120/1